

SKKT 330, SKKH 330



Thyristor / Diode Modules

SKKH 330

SKKT 330

Features

- Heat transfer through aluminium nitride ceramic isolated metal baseplate
- Precious metal pressure contacts for high reliability
- Thyristor with amplifying gate
- UL recognized, file no. E 63 532

Typical Applications*

- DC motor control (e. g. for machine tools)
- Temperature control (e. g. for ovens, chemical processes)
- Professional light dimming (studios, theaters)

1) See the assembly instruction

V_{RSM} V	V_{RRM}, V_{DRM} V	$I_{TRMS} = 510$ A (maximum value for continuous operation) $I_{TAV} = 330$ A (sin. 180; $T_c = 80$ °C)	
900	800	SKKT 330/08E	SKKH 330/08E
1300	1200	SKKT 330/12E	SKKH 330/12E
1700	1600	SKKT 330/16E	SKKH 330/16E
1900	1800	SKKT 330/18E	SKKH 330/18E

Symbol	Conditions	Values	Units
I_{TAV}	sin. 180; $T_c = 85$ (100) °C;	305 (225)	A
I_D	P16/200F; $T_a = 35$ °C; B2 / B6	520 / 650	A
I_{RMS}	P16/200F; $T_a = 35$ °C; W1 / W3	585 / 3 * 485	A
I_{TSM}	$T_{vj} = 25$ °C; 10 ms	9500	A
	$T_{vj} = 130$ °C; 10 ms	8000	A
i^2t	$T_{vj} = 25$ °C; 8,3 ... 10 ms	451000	A ² s
	$T_{vj} = 130$ °C; 8,3 ... 10 ms	320000	A ² s
V_T	$T_{vj} = 25$ °C; $I_T = 750$ A	max. 1,4	V
$V_{T(TO)}$	$T_{vj} = 130$ °C	max. 0,8	V
r_T	$T_{vj} = 130$ °C	max. 0,6	mΩ
I_{DD}, I_{RD}	$T_{vj} = 130$ °C; $V_{RD} = V_{RRM}; V_{DD} = V_{DRM}$	max. 85	mA
t_{gd}	$T_{vj} = 25$ °C; $I_G = 1$ A; $di_G/dt = 1$ A/μs	1	μs
t_{gr}	$V_D = 0,67 * V_{DRM}$	2	μs
$(di/dt)_{cr}$	$T_{vj} = 130$ °C	max. 250	A/μs
$(dv/dt)_{cr}$	$T_{vj} = 130$ °C	max. 1000	V/μs
t_q	$T_{vj} = 130$ °C	50 ... 150	μs
I_H	$T_{vj} = 25$ °C; typ. / max.	150 / 500	mA
I_L	$T_{vj} = 25$ °C; $R_G = 33$ Ω; typ. / max.	300 / 2000	mA
V_{GT}	$T_{vj} = 25$ °C; d.c.	min. 3	V
I_{GT}	$T_{vj} = 25$ °C; d.c.	min. 200	mA
V_{GD}	$T_{vj} = 130$ °C; d.c.	max. 0,25	V
I_{GD}	$T_{vj} = 130$ °C; d.c.	max. 10	mA
$R_{th(j-c)}$	cont.; per thyristor / per module	0,11 / 0,055	K/W
$R_{th(j-c)}$	sin. 180; per thyristor / per module	0,116 / 0,058	K/W
$R_{th(j-c)}$	rec. 120; per thyristor / per module	0,13 / 0,065	K/W
$R_{th(c-s)}$	per thyristor / per module	0,04 / 0,02	K/W
T_{vj}		- 40 ... + 130	°C
T_{stg}		- 40 ... + 130	°C
V_{isol}	a. c. 50 Hz; r.m.s.; 1 s / 1 min.	3600 / 3000	V~
M_s	to heatsink	5 ± 15 % ¹⁾	Nm
M_t	to terminals	9 ± 15 %	Nm
a		5 * 9,81	m/s ²
m	approx.	600	g
Case	SKKT	A 73b	
	SKKH	A 76b	

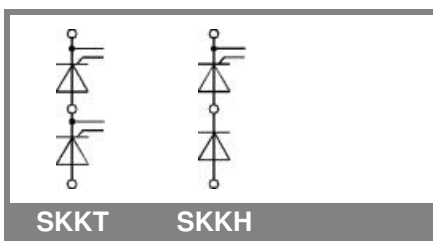

SKKT

SKKH

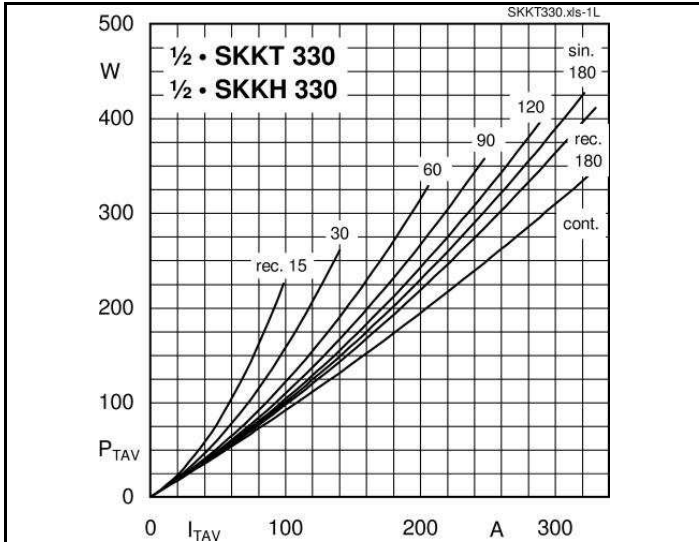

Fig. 1L Power dissipation per thyristor vs. on-state current

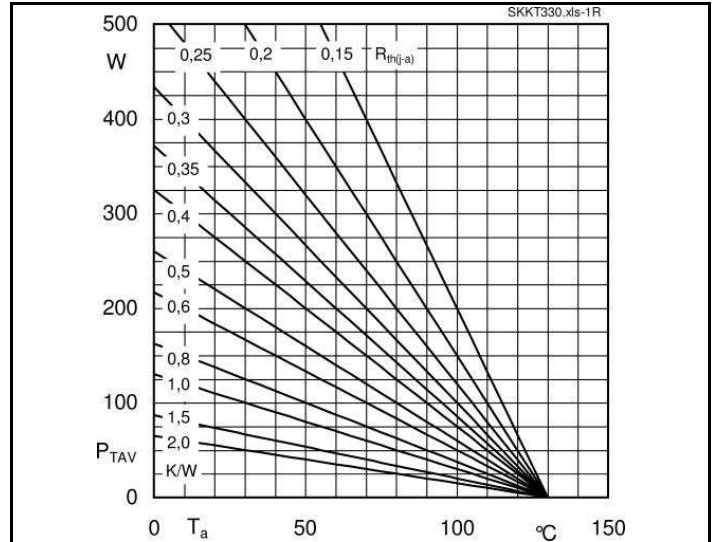

Fig. 1R Power dissipation per thyristor vs. ambient temp.

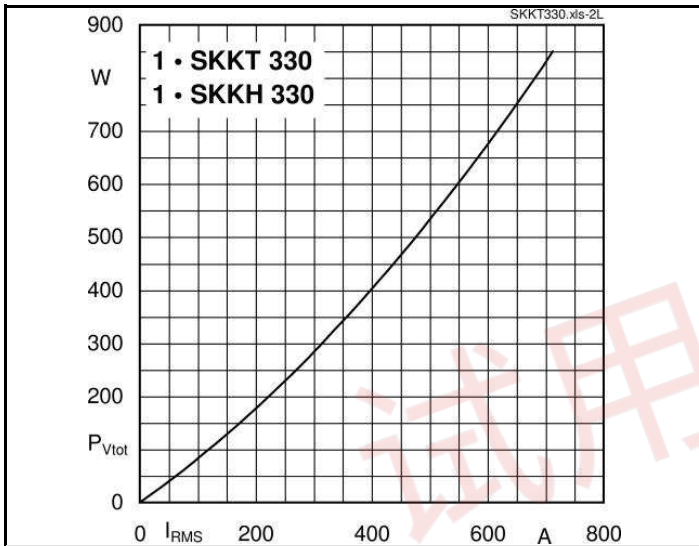

Fig. 2L Power dissipation per module vs. rms current

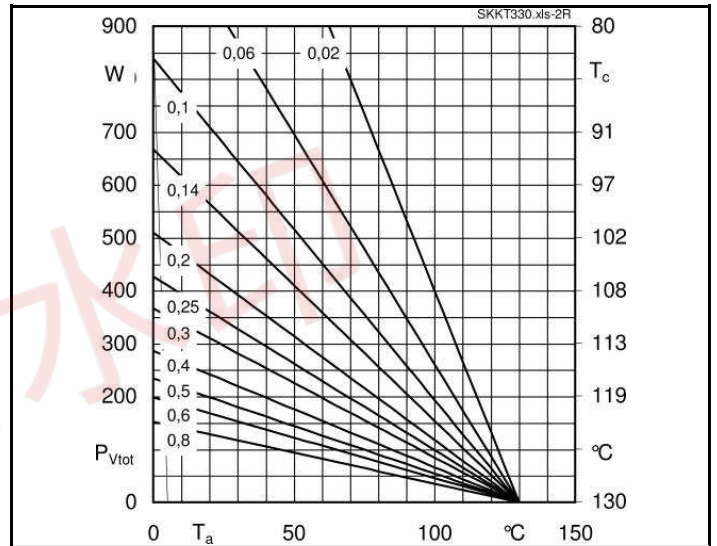

Fig. 2R Power dissipation per module vs. case temp.

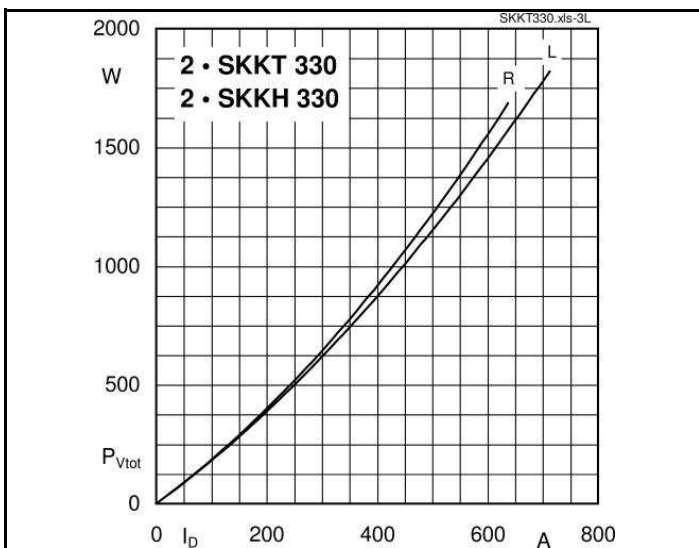

Fig. 3L Power dissipation of two modules vs. direct current

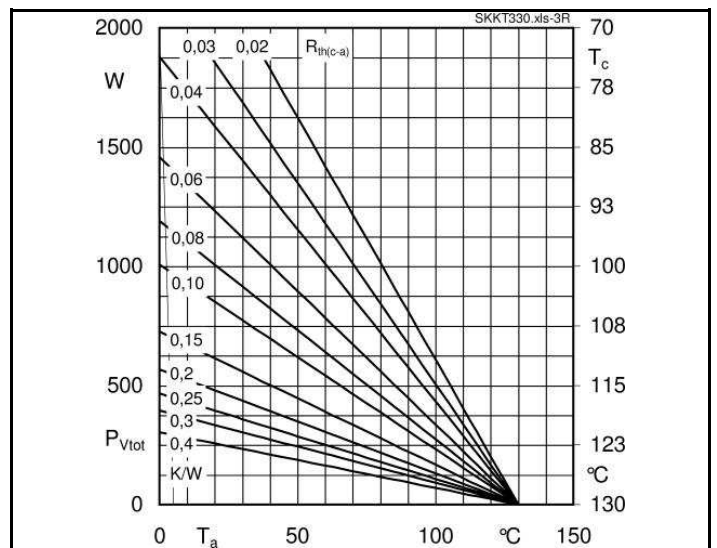
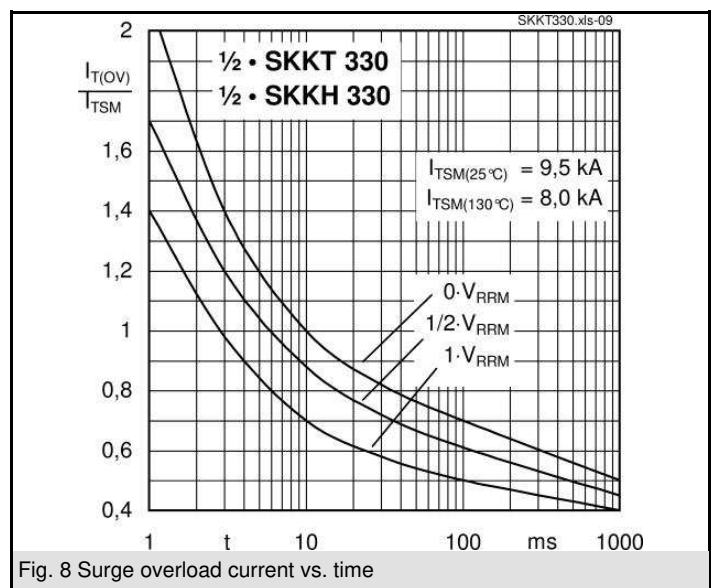
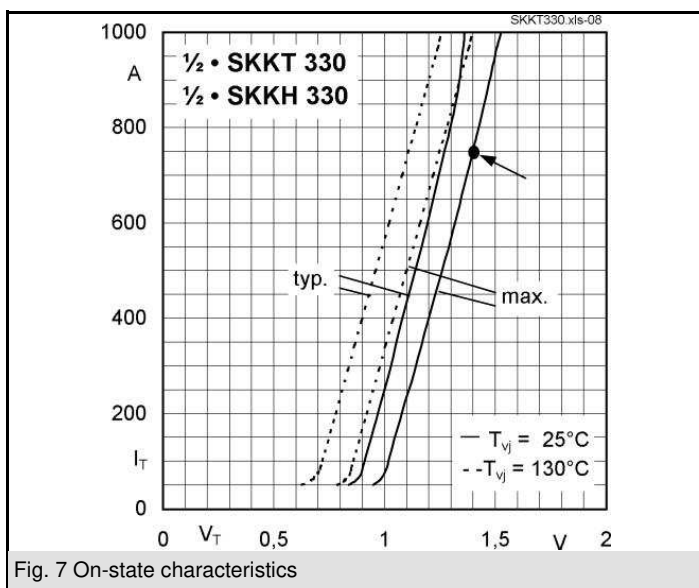
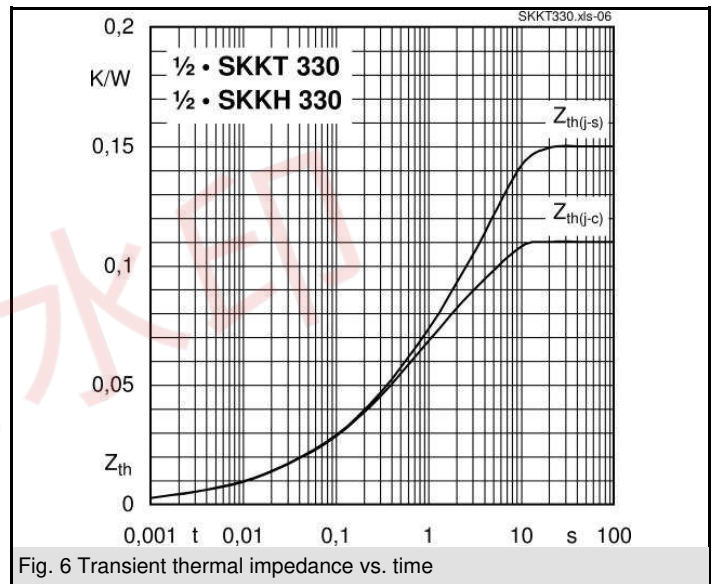
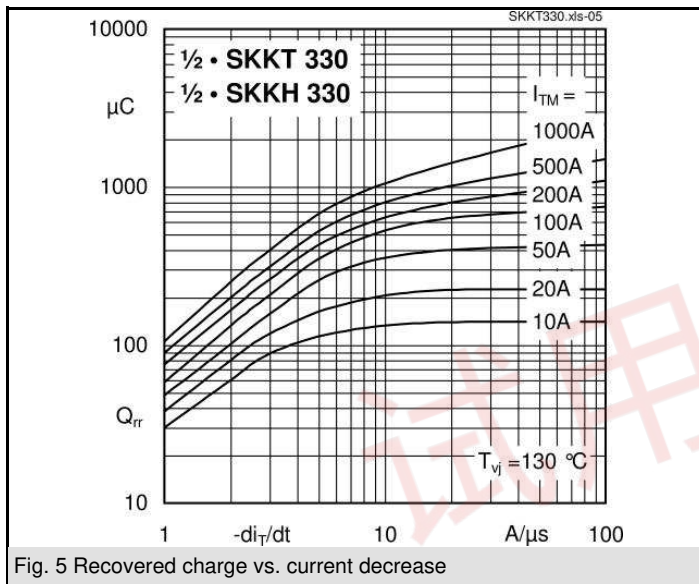
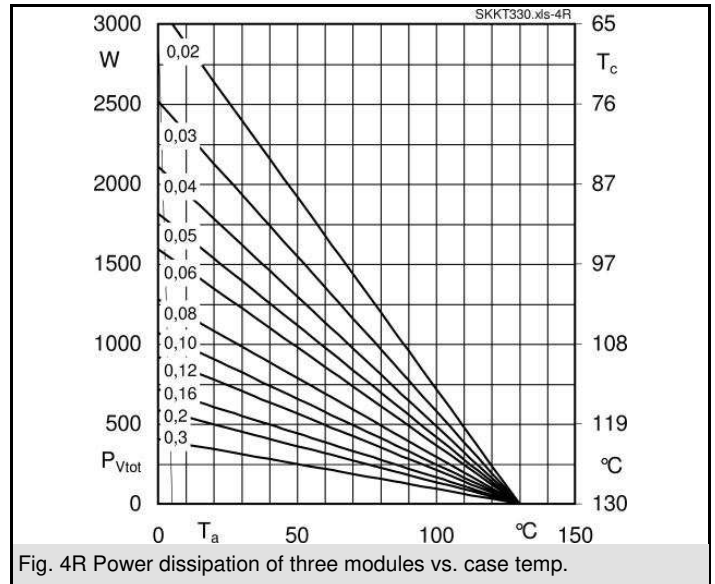
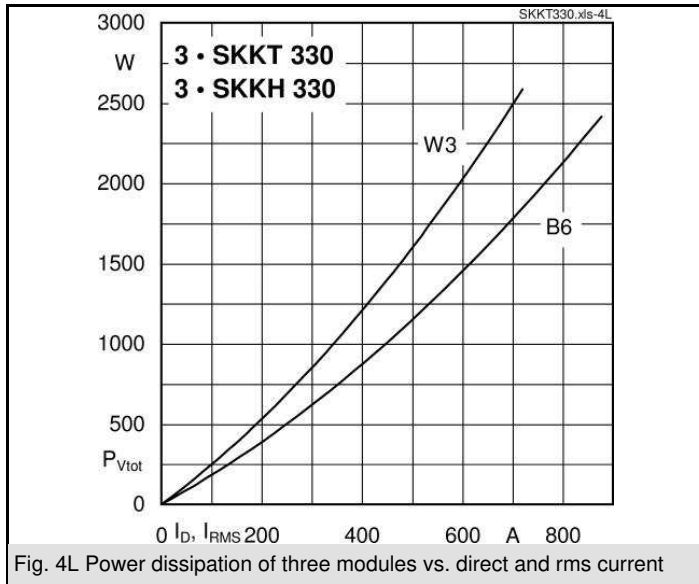

Fig. 3R Power dissipation of two modules vs. case temp.

SKKT 330, SKKH 330



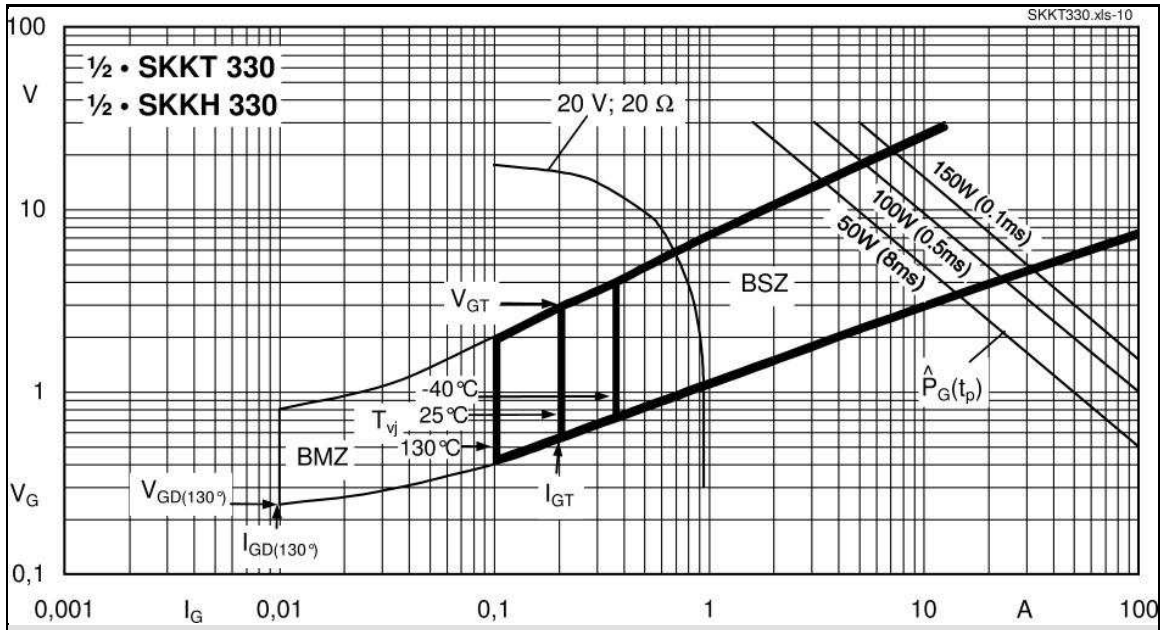
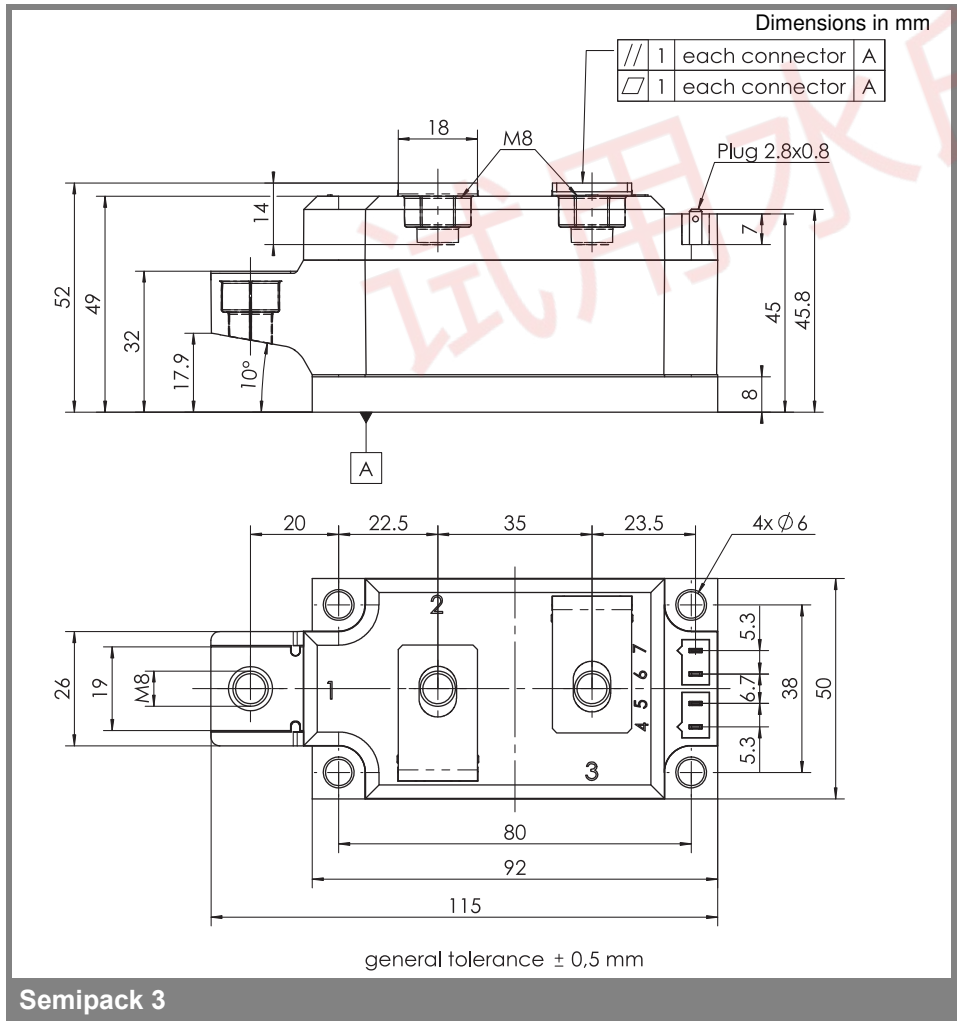
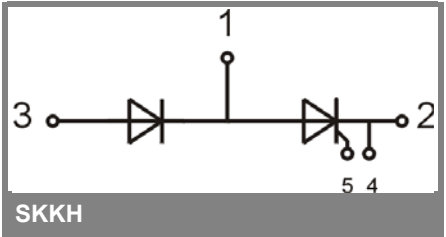
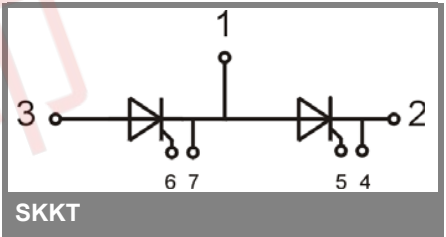

Fig. 9 Gate trigger characteristics



Semipack 3



试用水印